

AVANZ



NEWS

Fostering Vintage and Traditional Aeromodelling in New Zealand # 192





Committee Notices



#191 CONTENTS

Committee Notices

NDC

Coming Events

Tomboy rally

Past Events

Hummingbird reprise

Pylonius

Duster 1959

Dubious Tips

Bettair newsletter

Bleriot Monoplane

Three Questions

Memories

Shadow Planes

Cyklon 1943

Concealed DT

Leader Boards

The Last Straw

Nationals

The Big Event is fast approaching. Our Vintage programmes for Free Flight and Wireless Control is printed on page 5. It is a very full schedule that includes almost all events.

Tomboy Rally

SAM 2001 is hosting another international rally for the Tomboy design. Five different areas, 36" and 48" wingspans in IC and electric, plus floatplane. SAM 2001's flyer starts on page 5. Nine months to get you flights in, so no excuses about not having enough time.

Vintage SIG Chairman

Don is stepping down from this position after serving the interests of all Vintage fliers superbly for many years. The gap will need to be filled at the AGM to be held at the Nationals on Monday 2nd April - see programme.

CONTRIBUTORS

Wayne Cartwright
 Ian Harvey Allan Knox
 SAM 2001 Stew Cox
 Ross Gray John Danks
 Grayson Furniss

COVER: Tony Gribble with 1/2E Texaco *Folly 2* at the Airsail Rally, 10th September. See p.17

SIG CHAIRMAN	Don Mossop	donmossop@gmail.com	TREASURER	Jan Butcher	jjbutcher@xtra.co.nz
SIG SECRETARY	Don Mossop	donmossop@gmail.com	AVANZ News	Bernard Scott	scott.scott@xtra.co.nz
AVANZ Plans	Mark Venter	avanz.plans@xtra.cvz	MFNZ COLUMN	W Cartwright and D Crook	chloecat@xtra.co.nz
COMMITTEE	Wayne Cartwright	rwcartwright4@gmail.com	Barrie Russell	barrierussell@xtra.co.nz	Allan Knox allan.j.knox@gmail.com
	Peter Townsend	petert2@outlook.co.nz	Bryan Treloar	bryan_treloar@hotmail.com	Warner Summerton gsumm@gmail.com
	Tony Gribble	agrib@orcon.net.nz			

NATIONAL DECENTRALISED PROGRAMME

Vintage and Free Flight

October, November 2022

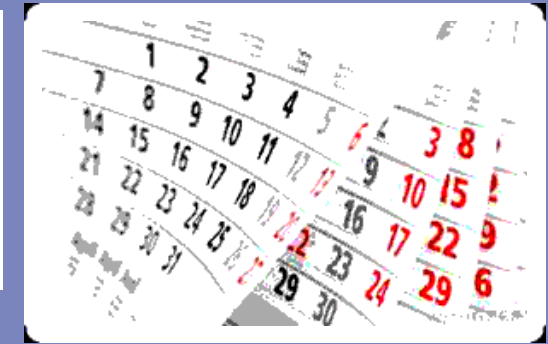

Oct/22	149	VINT	FF Vintage Hand Launch Glider
Oct/22	150	VINT	FF Vintage Catapult Glide
Oct/22	151	VINT	RC Vintage Open Texaco
Oct/22	152	VINT	RC Classical 1/2E Texaco
Oct/22	153	VINT	RC Classical E Texaco
Oct/22	257	FF	P30
Oct/22	258	FF	Hangar Rat
Oct/22	259	FF	Indoor Hand Launch Glider
Oct/22	260	FF	Tip Launch Glider
Oct/22	261	FF	E36

Nov/22	154	VINT	FF Vintage Glider Duration
Nov/22	155	VINT	FF Classic Glider Duration
Nov/22	156	VINT	RC Vintage E Rubber Texaco
Nov/22	157	VINT	RC Vintage 1/2E Texaco
Nov/22	158	VINT	RC Classical IC Duration
Nov/22	262	FF	A1 Glider
Nov/22	263	FF	Coupe d'Hiver
Nov/22	264	FF	1/2A Power
Nov/22	265	FF	Catapult Launched Glider
Nov/22	266	FF	Hand Launch Glider



Coming Events

Northern North Island Vintage RC Rally dates

The following dates have been set for Vintage Rallies. The format is to be a one-day event on a Saturday in which all or any classes may be flown. *NDC events for that month are in italics. NDC events for 2023 are based on this year's schedule (tbc).* In the event of unfavourable flying conditions on the first date, a decision will be made on the Thursday evening before and an email notice of postponement to the alternate date will be sent out.

Flying from 9am – 3:30pm. Registration fee of just \$5.00

Contact: Don Mossop (274940854) or Wayne Cartwright (0221534679)

Next ...

TUAKAU **Oct 8th** **Raindate Oct 15th**
[NDC: *V. Open-TeX, Cl. 1/2E-TeX, Cl. E-TeX*]

NGATEA **Nov 5th** **Raindate Nov 19th**
[NDC: *V. 1/2E-TeX, V. E-Rubber Tex, Cl. IC-Duration*]

NATIONALS **January 2nd - 6th** **Carterton**
[NDC: *Cl. 1/2E-TeX, Cl. E-TeX, Cl. Precision*]

NGATEA **Feb 4th** **Raindate Feb 11th**
[NDC: *V.1/2A-TeX, V. E-Rubber Tex, Cl. IC-Duration*]

AIRSAIL **Mar 4th** **Raindate Mar 11th**
[NDC: *V. IC-Duration, V. E-Duration, Cl. E-Duration*]

TUAKAU **Apr 8th** **Raindate Mar 15th**
[NDC: *V. 1/2 E-TeX, V. A-TeX, V. E-TeX*]

NSMAC* **May 6th** **Raindate May 13th**
[NDC: *Scale Texaco, V. Open-TeX*]

*North Shore MAC Green Road, Dairy Flat, Auckland



Vintage Nationals Programme

As of 28 September

90	Vintage	FFV01	Vintage FF Power Duration	FF	Mon Jan 2 - 7:00 a	Mon Jan 2 - 12:00p
91	Vintage	FFV02	Vintage FF Rubber Duration	FF	Mon Jan 2 - 7:00 a	Mon Jan 2 - 12:00p
92	Vintage	FFV08	Vintage FF Glider Duration	FF	Mon Jan 2 - 7:00 a	Mon Jan 2 - 12:00p
93	Vintage	RCV02	RC Classical Precision	RC3	Mon Jan 2 - 9:00 a	Mon Jan 2 - 5:00pm
94	Vintage	RCV16	RC Vintage Precision	RC3	Mon Jan 2 - 9:00 a	Mon Jan 2 - 5:00pm
95	Vintage	RCV03	RC Vintage IC Duration	RC3	Mon Jan 2 - 9:00 a	Mon Jan 2 - 5:00pm
96	Vintage	RCV14	RC Classical IC Duration	RC3	Mon Jan 2 - 9:00 a	Mon Jan 2 - 5:00pm
97	Vintage	SIGAGM	Vintage AGM & BBQ	Hall	Mon Jan 2 - 5:45 p	Mon Jan 2 - 6:45pm
98	Vintage	FFV09	Vintage and Nostalgia Small Power	FF	Tue Jan 3 - 7:00 ar	Tue Jan 3 - 12:00pr
99	Vintage	RCV06	RC Vintage 1/2 A Texaco	RC3	Tue Jan 3 - 9:00 ar	Tue Jan 3 - 5:00pm
100	Vintage	RCV04	RC Classical E Texaco	RC3	Tue Jan 3 - 9:00 ar	Tue Jan 3 - 5:00pm
101	Vintage	RCV05	RC Classical 1/2 E Texaco	RC3	Tue Jan 3 - 9:00 ar	Tue Jan 3 - 5:00pm
102	Vintage	RCV07	RC Vintage E Duration	RC3	Tue Jan 3 - 9:00 ar	Tue Jan 3 - 5:00pm
103	Vintage	FFV10	Vintage FF Cat	FF	Wed Jan 4 - 7:00 a	Wed Jan 4 - 12:00p
104	Vintage	FFV11	Vintage FF HLG	FF	Wed Jan 4 - 7:00 a	Wed Jan 4 - 12:00p
105	Vintage	FFV07	Classic FF Combined Duration	FF	Wed Jan 4 - 7:00 a	Wed Jan 4 - 12:00p
106	Vintage	RCV11	RC Sport Cabin E Texaco	RC3	Wed Jan 4 - 9:00 a	Wed Jan 4 - 5:00pm
107	Vintage	RCV15	RC Classical E Duration	RC3	Wed Jan 4 - 9:00 a	Wed Jan 4 - 5:00pm
108	Vintage	RCV13	RC Vintage E Texaco	RC3	Wed Jan 4 - 9:00 a	Wed Jan 4 - 5:00pm
109	Vintage	RCV01	RC Vintage A Texaco	RC3	Wed Jan 4 - 9:00 a	Wed Jan 4 - 5:00pm
110	Vintage	FFV12	Nostalgia FF Power Duration	FF	Thu Jan 5 - 7:00 ar	Thu Jan 5 - 12:00pi
111	Vintage	FFV13	Nostalgia FF Rubber Duration	FF	Thu Jan 5 - 7:00 ar	Thu Jan 5 - 12:00pi
112	Vintage	FFV14	Nostalgia FF Glider Duration	FF	Thu Jan 5 - 7:00 ar	Thu Jan 5 - 12:00pi
113	Vintage	RCV12	RC Vintage Open Texaco	RC3	Thu Jan 5 - 9:00 ar	Thu Jan 5 - 5:00pm
114	Vintage	RCV08	RC Vintage 1/2 E Texaco	RC3	Thu Jan 5 - 9:00 ar	Thu Jan 5 - 5:00pm
115	Vintage	RCV09	RC Vintage E Rubber Texaco	RC3	Thu Jan 5 - 9:00 ar	Thu Jan 5 - 5:00pm
116	Vintage	FFV03	Vintage FF Precision	FF	Fri Jan 6 - 7:00 am	Fri Jan 6 - 12:00pm
117	Vintage		RC Vintage Rain Date	RC3	Fri Jan 6 - 9:00 am	Fri Jan 6 - 12:00pm
118	Vintage	SIGPG	Vintage Prize Giving	VCC	Fri Jan 6 - 2:30 pm	Fri Jan 6 - 3:30pm

NEXT MONTH !

Indoor Flying at Morrinsville

Sunday October 16, 2022

Highlight the date in your diary!

- **Hangar Rat • HL Glider**
Flown to MFNZ free flight rules
- **Modelair Hornet**
Flown to AMAC rules.
- **F4F Peanut Scale • F4D Rubber Scale**
Flown to FAI rules. Refer to the link on the MFNZ website under FF&CL SIG
- **Memorial Scale • Kit Scale**
Flown to MFNZ rules. Refer to the link on the MFNZ website under FF&CL SIG

Venue: Westpac Stadium 21 Ron Ladd Place, Morrinsville

Programme: **10.00** Hangar Rat, Hand Launched Glider and Modelair Hornet
Scale static judging until 12.30pm

12.30 F4F Peanut, F4D Indoor Open Rubber Scale, Kit Scale and Memorial Scale All run concurrently.
Scale flying ceases at 3.15pm

3.45 Placegetters announced and certificates awarded. Please stay for this.

Flyer's entry \$20.00

Contact Stan Mauger 09 575 7971, stanm09c4@gmail.com for further information



Organised by the Auckland Model Aero Club Inc
in conjunction with the Scale Free Flight & Control Line SIG

NEXT YEAR !

WAIKATO FREE FLIGHT CHAMPS

SATURDAY 4th March 2023
PROCTOR ROAD, ORINI 8.00am start Fly-offs 2.00pm

VINTAGE DESIGNS MAY BE USED IN ALL EVENTS

AGGREGATE	10:30 - 11:00 am
OPEN	3 x 180 (Power, Rubber, Glider)
KIWI POWER	3 x 120
CAT	6 x 60
E-36	3 x 120
MINI Combined	3 x 120 (P-30, Coupe d'Hiver, 1/2A, A1)

L'AQUILONE SAM 2001
TOMBOY RALLY INTERNATIONAL POSTAL CONTEST
01/07/2022 – 30/06/2023

We wish to present this competition to all the lovers of this nice model with the only aim of having fun in a postal contest which is organized to provide some fun flying together or at the same time as are all postal contests. The Tomboy Rally wants to prove the performance of this model alongwith the ability of the builder and pilot, without reaching the peak agonism of usual contests and only wishing to fly the model having fun in a relaxed manner. After having carried out some tests we have decided to admit the use of i.c. engines and electric motors trying to reduce the gap between them.

Model

- The **36" or 44"** wing span (as per plan Aeromodeller) and **48"** (as per Boddington plan or 36 " scaledup) models are admitted;

- - Models may be fitted with floats as per plan (scaled-up for 48" version);
- - no minimum weight;
- - reinforcement or lightening of the structure with respect of the basic outline of the original model are admitted;
- - materials to be used are those found on the plan;
- - plastic covering in place of tissue, silk or other is admitted.
- - More than one person can use same model;
- - Same model can flight in L.G. or float version;
- - Lone fliers can self launch an time

Engine/motors

I.c. engines and electric motors are admitted within the following limits:

36"-44" WINGSPAN

I.C. Engines:

- Any engine with 1 cc. maximum displacement;
- Fuel tank : 3 cc.
- R/C carburettor is admitted.

Electric Motors:

- Any electric motor is admitted with direct drive
- The engine cannot be stopped and started again: the motor must run continually without interruptions till the end of the battery charge or competitor's decision;
- no folding prop is admitted; if a folding prop is used the blades must be held open with a rubber band;
- freely assembled admitted batteries:
- **-450 Mah 2 cell LiPo**
- separated batteries pack for Rx alimentation is allowed

48" WINGSPAN

I.C. Engines:

- **Any engine with 2, 5 cc. maximum displacement;**
- **Fuel tank : 6 cc.**
- R/C carburettor is admitted.

Electric Motors:

- Any electric motor is admitted with direct drive

International Tomboy Rally

- The engine cannot be stopped and started again: the motor must run continually without interruptions till the end of the battery charge or competitor's decision;
- no folding prop is admitted; if a folding prop is used the blades must be held open with a rubber band;
- freely assembled admitted batteries:
- -500 Mah 3 cell LiPo
- separated batteries pack for Rx alimentation is allowed

Flights and results

- Each competitor may fly as many flights as wished during the admitted period but only the best flight will be considered for the final result.

- Hand launches are admitted.

- The flight time start when the model is released or takes off. The flight time ends when the model lands or hits a fixed obstacle. In case the model flies out of sight the timekeeper will time for 10 seconds after losing sight of the model . Timing will continue if model is seen again or stopped after 10" deducting this time from the total time of the flight.

Awards :

A diploma for all competitors and prizes for the first three in each version rank. Special prize for best flight in float version.

Results

Results, address, photos and technical specification about model must be forwarded to the Organization within the 15th July 2023 to Curzio Santoni (cusanton@tin.it) or to Gianfranco Lusso (gfl@orange.fr). Many pleasant flights and happy landings to ALL !!!!

SPECIAL PRIZE VIC SMEED

SAM 2001 have scheduled an extra Diploma that will be awarded to the best flight in Tomboy floatplane version (**36",44" or 48"**) taking off from water. The Editor will send to the winner a Diploma signed By SAM 2001 President and a bottle of special Italian Wine to drink to Vic Smeed!
Good ROW and fligth

SPECIAL PRIZE DAVID BECKER

The 2012 was the 5^o edition of SAM 2001 Tomboy Rally and we have scheduled a special prize for the three best flights obtained with 36" Tomboy F/F. Only engines diesel max 0.75 c.c. shall be used. The other rules are the same for **36" or 44"** wingspan type. It is possible to use a R/C Tomboy, however, being this a free-flight contest, the time must be stopped when transmitter is used, since the aircraft model should fly freely from any control from the ground.

Good thermals

TOMBOY RALLY PALMARES

2008/2009			
Pietre Moerkerken	Australia	24'12"	versione 36"
2009/2010			
Gino Ursicino	Italia	35'20"	versione 36"
2010/2011			
Ugo Baldari	Italia	47'02"	versione 36"
2011/2012			
Ugo Baldari	Italia	39'40"	versione 36"
Brian Deason	Australia	34'43"	versione 48"
2012/2013			
Brian Deason	Australia	25'35"	versione 36"
Brian Deason	Australia	41'29"	versione 48"
2013/2014			
Dete Hasse	Australia	33'12"	versione 36"
Brian Deason	Australia	38'22"	versione 48"
2014/2015			
Ian Dixon	Australia	19'54"	versione 36"
2015/2016			
Brian Deason	Australia	26'46"	versione 36"
Brian Deason	Australia	37'08"	versione 48"
2016/2017			
Gianfranco Lusso	Svizzera	28'26"	versione 36"
Les Davis	Australia	47'57"	versione 48"
2017/2018			
Gianfranco Lusso	Svizzera	30'55"	versione 36"
Brian Deason	Australia	30'48"	versione 48"
2018/2019			
Gianfranco Lusso	Svizzera	34'52"	versione 36"
Gianfranco Lusso	Svizzera	37'10"	versione 48"
2019/2021 (Covid-19)			
Stephane Courvoisier	Francia	21'35"	versione 36"
Gianfranco Lusso	Svizzera	24'45"	versione 48"

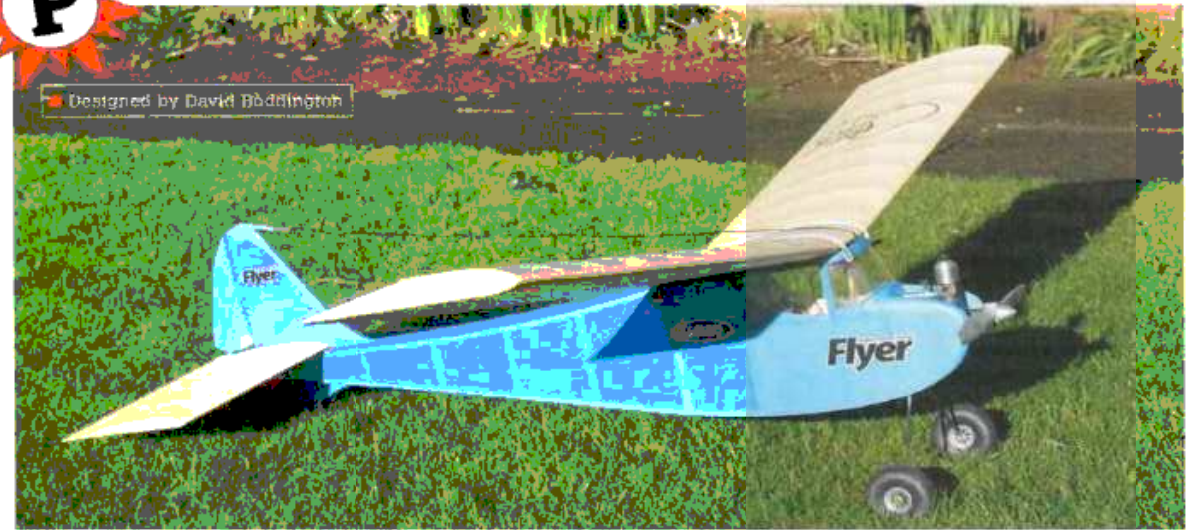

Tomboy Senior

Vic Smeed's classic design enlarged to 48" wingspan for 1.3 to 2cc engines - R/C optional.

It is incredible to realise that the 'Tomboy' Design has now been around for the best part of sixty years and that the model and the designer are still going strong. Always a free flight favourite, as witnessed by the Middle Wallop Hilda Baker Tomboy events, it has now had another new lease of life with the Tomboy 3 radio control competitions - you can find more information on these events in the April 2007 (Update for 2008) issue of RC Model Flyer.

The original 36" wingspan 'Tomboy' has the advantage of being compact, easily transported, it will fit in any car and won't break the bank in building costs. When fitted with a Mills .75cc diesel engine the performance, even with lightweight two-function radio fitted, is quite brisk and with a full complement of the 3cc fuel tank it will achieve a considerable height. If that altitude is then enhanced by finding a thermal, the apparent size of the model diminishes to the extent that some of us visually challenged old b*****s are having a problem in seeing its altitude. Having a model a little longer and a little lower down should ease that problem, although the real reason is to have another model to fly in competition with our fellow enthusiasts.

Similarities

Increasing the 'Tomboy' by 30% presents very few problems, it returns the same basic structure and design and the 3/16" wood components are upped to 1/4". The few minor modifications include:

- * A slightly reduced dihedral.
- * Engine bearers extended to the second bulkhead.
- * Sheeting under the nose omitted to allow easy access to the engine bolts for thrust line adjustments
- * Height of undercarriage reduced by 1/2", it was getting a bit stinky.
- * Wing centre section top sheeting extended one bay each side
- * Nose area reinforced with 1.5mm plywood side plates.... And allowances made for radio control, although it is equally suitable for free flight.

If you are just building the 'Tomboy Senior' as a sports RC model, any engine from a '10' to a '15' glow, or the equivalent diesel will do, having a throttle equipped motor will give more flying options. I don't recommend fitting ailerons, for them to be effective you would have to severely reduce the dihedral and it wouldn't then have the same 'Tomboy' character.

Tomboy Senior competition

For flying in the competition the model must be built exactly as per plan and must be powered by a Mills 1.3cc diesel with a standard tank. The engine can be an original Mills (Mills 1 or 2) or an Indian Aurora, Irvine, or other replica, but no modifications to the engine are allowed. A Graupner 9" x 4" gray propeller is to be fitted, an operable fuel cut-off is optional. 2-1/2" diameter balloon wheels are to be fitted and the model must be fabric covered i.e. 'Tex' materials, or nylon, etc. These rules are introduced to give, as far as possible, an equal start, model-wise, in the competition and to place the emphasis on flying skills - plus a bit of luck!

All clear? Good, clear the bench and let's get building. I prefer to cut out all the parts before commencing construction, including sanding the edges of formers and ribs and bending the undercarriage, which is still sewn and epoxied to the fuselage former in the time-honoured way. One further piece of advice: The model will almost certainly finish tail heavy, so keep the rear end and tail surfaces as light as possible.

Fuselage

Where there are curvatures in the longerons, I prefer to laminate them, using two pieces of 1/8" x

1/4" and dampening them before bending. This not only makes the forming of the curves easier but, with a liberal application of PVA glue between the laminations, makes for a stronger and more stable structure. Protect the plan with clear plastic film and pin and glue the longerons and uprights in position, it is also helpful if you have also determined the radio layout at this stage. My recommendation is (as shown on the plan) to have 1/4" square hardwood side rails to which is screwed a 1.5mm ply plate housing the receiver, servos and switch. Keep the installation fairly high in the fuselage so that it is easy to access it from the wing seating area; the switch is actuated by a piece of pianowire projecting through the fuselage side. Because of the tail heavy tendency, the battery should be positioned as far forward as possible.

With the first side assembled and the glue has set, remove it from the building board, reverse it and protect the top with clear film. The second side is then built directly over the first, producing a 'good' external surface for the left and right hand sides. When the side frames are glued in position, followed by adding formers F1, F3

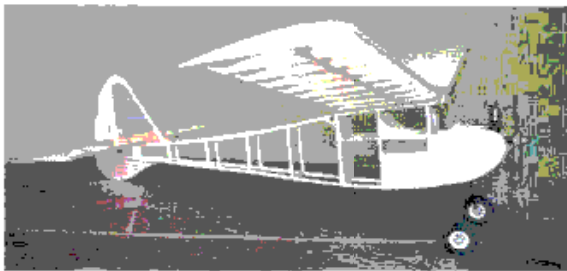

Looking smart in its uncovered state. Mills 1.3 diesel is bolted in place with a touch of right side thrust.

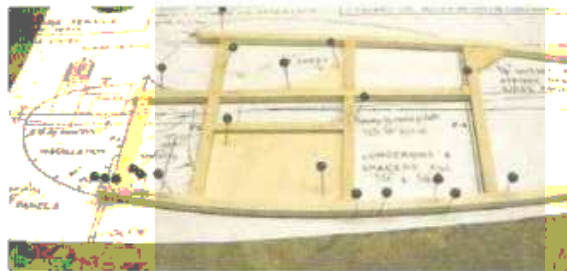

The right hand fuselage side is pinned down over the plan and over the first side, using protective clear film between.



Sand the 'rough' side of the fuselage sides before joining.

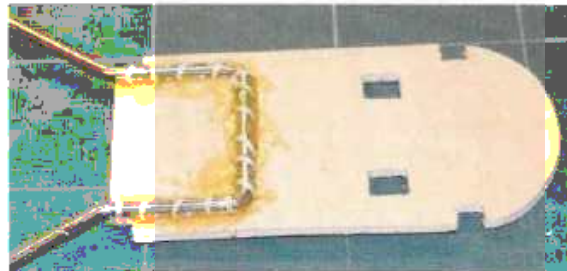

Bind and epoxy the planowire undercarriage to former F1.



Formers are glued to the right hand side, checking for verticality, before adding the left hand side.



Gluing the nose side cheeks and engine bearers in place



Fixing supports for the elevator control snake

and F4 to one side, checking that they are at right angles. When dry the second side can be added to the formers, using a building jig if possible, otherwise pinning over the plan view of the drawing and clamping the sternposts of the fuselage together. Add the 3/8" square engine bearers and the side nose sheeting before adding the top and lower crosspieces to the rear. The nose area is completed by gluing the 1.5mm plywood and 3/8" balsa cheeks in place, plus F2 and the 0.4mm plywood (or 1/32" balsa) coaming. Sheet the top and lower areas to the fuselage in the tail area with 1/8" balsa, also behind F1 on the underside and complete the front of the top cabin with scrap balsa.

Wings

You can make a choice here between building the wing in one piece, starting with the centre section and adding the dihedral brace and outer panels, or constructing the centre section and

outer panels separately and joining them with the dihedral brace. I prefer the latter method as it allows you to trim the top sheeting before joining and you can also prop-up the outer panels to the correct dihedral. Construction follows the original 'Tomboy' and is absolutely standard use hard balsa for the leading and trailing edges and spar. I had run out of 1/4" trailing edge stock and used 3/16" with 0.8mm ply laminated to its lower surface it gave a stiff, strong trailing edge. Only balsa only reinforce the top at the centre section with 0.8mm ply pieces to prevent the wing bands from cutting-in.

Tail Surfaces

Differences between the original size 'Tomboy' and the 'Senior' consists of having two tailplane centre ribs, for housing the fin and gluing strips either side of them so that the tailplane can be glued to the fuselage. The fin base is shaped to fit over the tailplane spars and

the structure is designed to allow for the rudder, if the model is to be flown free flight the tail surfaces can be banded onto the fuselage and only the top of the rudder made adjustable for flight trimming; the elevator is omitted.

Covering and Finishing

As previously stated, for competition purposes the model has to be covered with a fabric material - for other purposes, choose whatever suits you best. It is a matter of conjecture whether you glaze the cabin area and then fit the front wing dowels, or vice versa, if you fit them afterwards do ensure that they are glued in position and partly extend through former F3. Fuel proof the engine bay well and although dopes and other coverings are normally fuel proof it helps to keep the model clean by proofing it overall.

Radio Installation

Again, harking back to the weight considerations I would advocate closed loop control of

the rudder and lightweight control snakes for the elevator, no heavy pushrods, please. I don't install any allowance for adjusting the rudder, that provided by the transmitter should be adequate; the elevator can be adjusted at the servo, but it is rare that this is needed. You may think that sewn hinges are old fashioned, maybe they are but they still provide the lightest and most free of all hinge types.

Flying

I started off with the balance point at 20mm behind the rear edge of the main spar (the model being in a slightly nose down, gliding attitude). My prototype models weighed either side of 850g (1lb. 4oz.) and needed lead ballast on the nose to achieve the correct balance.

After the usual range and control function checks it was time to start the engine, not normally a difficult task with the Mills 1.3cc motor. Hand launching is the norm with Tomboys and John pushed number one gently in the air - and it was



freebee plan Enlarged Vic Smeed Tomboy

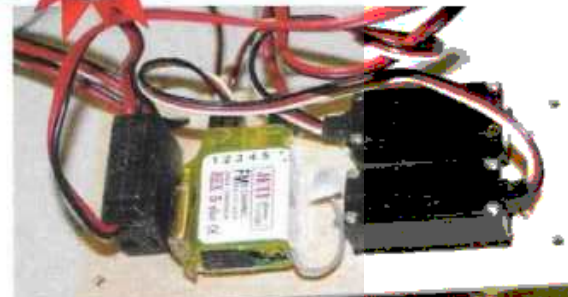

Radio installation plate is screwed to bearers on the fuselage. The rx is fitted on the bottom of the tray.

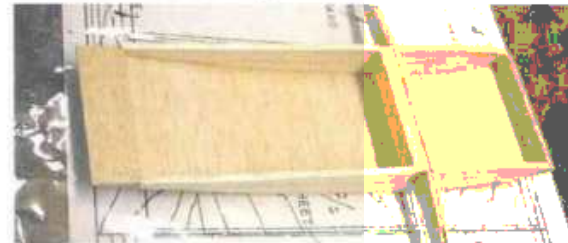

The ply dihedral brace is fitted ready for building the outer panels...



...the second panel is then built, propping up the first panel.

a glorious crisp winters day, with no wind, or so we thought. Climb-out was good and I was slightly surprised to see the Tomboy Senior climbing at about the same rate as the 36" version, I had expected it to be a little slower at gaining altitude and it may well be in windier conditions where you have to trade off height for forward penetration. Rudder and elevator controls were harmonious the rudder could do with slightly less movement and the 3/4" chord elevator is preferably adequate, a larger one could lead to over controlling. For the glide a little up elevator trim had the model descending steadily at just above the stalling speed, just right for achieving the best duration. John was now flying the model, which gave me a chance to take some photos as she came gracefully into

land. The object of the next flight was to decompress the Mills 1.3 so that at the lower power the model could be flown around at low level and I could take more pics, in the scramble to get the tank filled for a maximum flight time the model was launched, it climbed slowly into the ether, BUT without the radio switched on! Yes, I know, we must be a couple of stupid old gits, but I've done it before, in my single channel days and may well do it again. Suffice it to say that the model made its way unerringly towards an industrial estate and unless somebody has 'pocketed' it, there it remains, lovely Mills 1.3 and all.

The following day I took out TS no.2 and this time no problems, the performance was equal to the

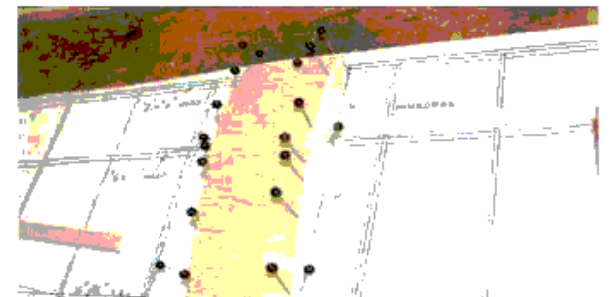

Construction of the wing in one piece, starting with the centre section...



Tilt the centre section so that the lower edge of the ply brace is flat on the board and build the first panel...



The tail control surfaces are 'sewn' hinged - the oldest - and best way.

first model, the control positive and the orange/vintage Solartex colour scheme looking great in the pale winter sunshine. With power reduced John was able to potter around at a lower altitude, for photography and all the landings were 'to the feet'. A most enjoyable and rewarding exercise. Having proven the Tomboy Senior concept I have no doubt that we will go on and have competitions for this class in addition to the pleasant, slow flying sports model this one should fit the bill. If you can find a Mills throttle you can install a third control and if the model is only for sports flying you don't have to use a Mills, although some form of diesel would seem appropriate.

FINAL WARNING, Please remember to put your name and

address on the model, you too can be an idiot, like the rest of us.

PS - I flew the 'Tomboy Senior' with 1/4" elevator movement, up and down, and 3/4" rudder movement left and right, measured at the rear base of the rudder. You might think that the balance point is a little rearward, but it worked well for me.

PPS - The week following the loss of 'Tomboy Senior' no. 1 I had a call from a fellow club member who happened to work on the industrial estate and guess what? It had been found in a small wooded area outside the factory, it was unharmed and the radio still worked fine - when it was switched on! I have no doubt that Ken Swales was up there, looking down and muttering, "Lucky git, Boddo". ☺

TOMBOY



DESIGNED BY
V. E. SMEED.
COPYRIGHT OF



THE AEROMODELLER PLANS SERVICE
THE AERODROME, STANBRIDGE, OR LEIGHTON BUZZARD BEGS.

ALL WOODS ARE BALSA UNLESS OTHERWISE STATED

THE 36" VERSION IS SUITABLE FOR ENGINES OF 1.5-1.0 CC. FOR ENGINES OF 1.0-0.5 CC. INCREASE SPAN AS SHOWN & USE HARD BALSA THROUGHOUT. NO CHANGE OF PLAN IS REQUIRED WHEN CONVERTING TO FLOATS. IT IS ADVISABLE TO FUEL PROOF THE ENTIRE MODEL FOR WATER FLYING REMOVE MOTOR CLEAN & OIL AFTER EACH DAYS FLYING.

- MATERIAL LIST**
- 5 STRIPS OF 3/16" X 3/16" MED
 - 2 " 3/16" X 3/16" HARD
 - 1 " 3/16" X 3/16"
 - 1 Y (SHAPED) 2" X 3/16"
 - 1 " 3/16" X 3/16"
 - 2 SHEETS OF 1/2" X 3/16" MED
 - 1 PACKET OF BALSA REJECTS CONTAINING 1/8" & 1/16" SHEET
- 36" VERSION**
- 15' OF 18 SWG PIANO WIRE
 - 3' " 1/8" DOWEL
 - 5' " 3/16" X 1/8" HARDWOOD
 - 12' " 2 1/2' CELLULOSE
 - 1" 4' " 1/8" PLY
 - CEMENT, RAG, TISSUE, DORE
 - BOLTS 2" AIRWHEELS OR RUBBER WHEELS, PINS, ETC

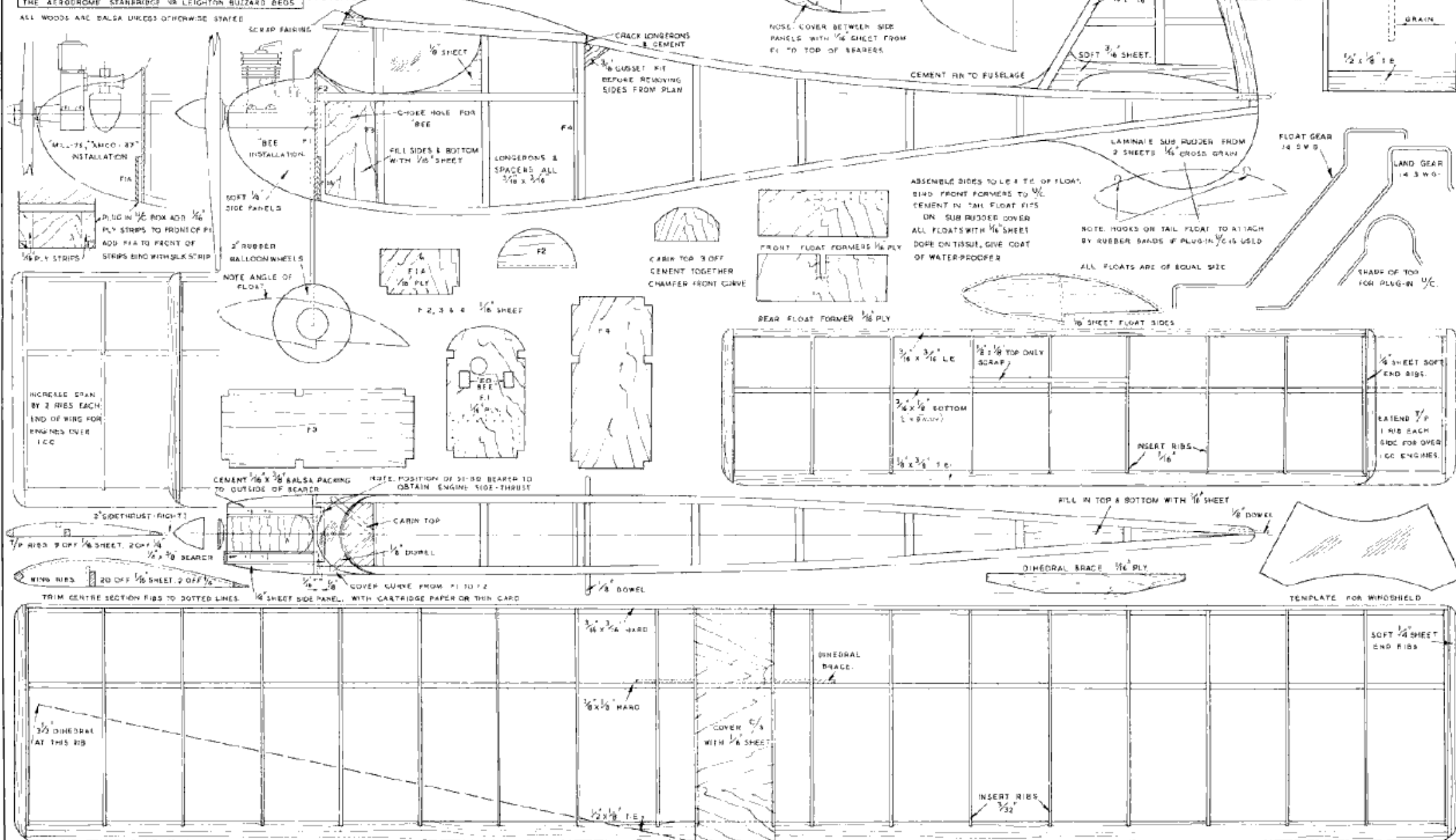
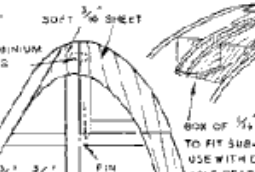
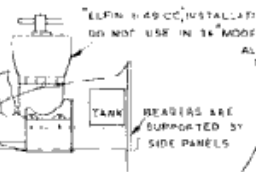

Bob Burling Memorial Vintage Event

Levin, Saturday 13th November

Report by Stew Cox

Photos by Ross Gray

After two postponements of this event in May, and as the Gareth Newton event earlier in the year also wasn't able to be flown, it was decided that we would look to still run the Levin Club's Bob Burling Vintage Event on the next available Saturday with suitable weather. When we made this decision back in May, we didn't anticipate that the first suitable Saturday would end up being in mid-August, such has been the unusually wet and windy winter in these parts.

The weather that transpired was well worth waiting for with attendees treated to a beautiful winter's day at Levin with light winds all day and a few small thermals. Despite all the previous winter rain the Levin field had drained very well and was completely dry underfoot. The farmer had even been able to cut a big chunk of the field for silage in the days before the event.

The downside of waiting for suitable weather was that we were only able to give a few day's notice to the email list of Vintage fliers in the lower North Island. As a consequence, six regulars were unable to attend due to prior commitments and holiday travels. However, we still had a pleasing turnout of 11 attendees

with models, nine of whom put in competition flights. Five of the eleven were new to the Levin Vintage events and there was good representation by Levin club members both participating and spectating.

Many attendees had brought more than one Vintage model and in addition to competition flights, there was quite a bit of Vintage sport flying. Six clubs were represented on the day across competition and sport fliers.

Highlights of the day:

+ Levin Junior Dominic Moyle flying in his first competition after Joe Bradbury brought along a Junior 60 for him to fly. Dominic nailed the spot on his first ever competition flight!

+ Ian Crozy Crosland bringing along his latest impeccable build for its maiden flight, a 60 inch Veron Deacon. It flew "off the board" and had great presence in the air.

+ Dave Crook attending a Levin event for the first time having shifted to Taranaki from more northern parts. Dave is looking forward to becoming a regular at these Levin events.

+ New Levin President Kevin Daly flying a Vintage event at Levin after many years.

+ Wayne Lightfoot and Graeme Lovejoy, both of the Feilding Model Flying Circle flying lightweight free flight rubber models in the perfect conditions. Both entered into the Vintage spirit flying 1939 Modelair Sportsters. Wayne also flew a Modelair Red Bird Junior, a design his father Stuart used to fly in his youth, the model being of similar vintage to the Sportsters. Also appropriate to fly on a calm winters day was Wayne's Coupe d'Hiver, a French design called Loque Bis from the mid sixties. Coupe d'Hiver is a challenging class developed by the French and translates to Winter Cup.

+ Terry Beaumont had with him a new free flight Lulu to which he has added a motor to enable it to be flown in Aggy at the Nats.

+ Levin's Club Secretary, the hard working Linda Lambess, organising a great sausage sizzle. It's great to see Linda back and recovering well after a major health issue! The chatting and banter that went on during the BBQ typified the relaxed low key nature of the event.

... continued

All who put in competition flights flew Precision. Dave Crook and Kevin Daly made the flyoff and both made excellent flyoff flights with Dave only one second off a perfect score with his electric Lanzo Bomber. John Miller was the only other flier in Precision to make the spot on each flight, the spot proving elusive to most despite the light wind conditions.

Three managed to record some scores for IC Duration although John and Ian ran out of time to record three scores while others hoping to fly Duration also ran out of time to record any scores, in some cases due to the length of their earlier flights.

Dave Crook's electric Dixielander flew very well and floated gracefully above with its translucent covering showing off the structure against the clear blue sky to easily make a perfect score.

Bryan Treloar had engine issues and so Stew Cox was the only one to fly 1/2A Texaco. His Cox Babe Bee was running for up to 8 minutes from a standard tank although the revs were so low that the model needed to be steered into thermals to climb to a safer height. Stew went on to make a 17 minute flyoff flight.

The last of the Levin Club's Vintage Events for 2022 is the John Selby Memorial on Saturday 15 October 2022 (Saturday 22 October wind postponement date). Hope you can make it !

Results

Vintage Precision

Dave Crook	New Plymouth	Lanzo Bomber	600 + 199
Kevin Daly	Levin	Buzzard Bombshell	600 + 195
Stew Cox	Wellington	Brooklyn Dodger	580
John Miller	Kapiti	Buzzard Bombshell	572
Terry Beaumont	Kapiti	Lanzo RC1	564
Joe Bradbury	Levin	Viking	559
Bryan Treloar	Ashurst	Red Zephyr	555
Ian Crosland	Kapiti	Mercury	546
Dominic Moyle (Jnr)	Levin	Junior 60	515

Vintage IC Duration

Kevin Daly	Levin	Buzzard Bombshell	445
John Miller	Kapiti	Buzzard Bombshell	240
Ian Crosland	Kapiti	Mercury	151

Classical E Duration

Dave Crook	New Plymouth	Dixielander	900
------------	--------------	-------------	-----

Vintage 1/2A Texaco

Stew Cox	Wellington	Playboy	1500 + 1020
----------	------------	---------	-------------





Enlarged 1939 *Modelair Sportster*
Graham Lovejoy



Loque Bis. French Coupe d'Hiver
Wayne Lightfoot



Hardworking Levin Secretary Linda Lambass
put on a great sausage sizzle



Joe Bradbury and Dominic Moyle



Kevin Daly *Bombshell*



Jack Wilkinson *Red Zephyr*

Ian, Terry, Kevin, Bryan, Dave

Dave Crook *Bomber*

Dominic Doyle *Junior Sixty*





Left: Terry Beaumont with his diesel powered *Lulu* (!?!) for Nationals Aggregate event.



South Island Free Flight Camps *(in which there were Vintage models)* July 30th - 31st 2022



Far Right: E-36 launch

Right: Fatty and Skinny timing that flight, only a minute and barely in sight. Photographs on right (and captions) by Ian Harvey.

Below: The Southern Alps were always in sight.

Bottom: Neither snow nor rain nor wind nor endangered lizard species could stay the dohty fliers from their contest flights.





Above: Lynn Rodway preparing his *Mamselle* for Kennedy Precision.

Below: Stylish tailplane hinges engineered by Julius Long for his *Simplex* models.



Above: The mylar was almost horizontal for most of Saturday, but there was no rain.

Below: Paul Squires' elegant model boxes enabled the compact packing needed to fly down to the event.



Above: Nigel McAnelly with *Aggregate* model that flew away just before the event ended.

Below: Peter Jackson dropped by in one of his restored masterpieces. No, hang on, this one was in the Omaka Aviation Heritage Centre. Always worth return visits.



Vintage Rally 10th September 2022

JR AIRSAIL, Pukekawa

The predicted afternoon showers came a little early, but those that attended enjoyed the beautiful location of the Airsail field. Many thanks to John Danks for again hosting this rally.



Wayne Cartwright Classical Duration **Nig-Nog - 850**
(Another Leader Board Top-10 qualifying score)

Dave Wilkins Vintage IC Duration **Demon - 1376**
("This is going straight to the **top** of the IC Duration Leader Board!")

Robert Berger Vintage Precision **Junior 60 - 574**
(A Leader Board Top-10 qualifying score)



WAIT FOR IT
WAIT FOR IT !!!

Back, I say. Back,
you crazy Demon !!

I can nae hold her
much longer Cap'n. Her
deuterium levels are
fallin' - she's gonna blow!



A tense
moment
with the
Demon



Mike Mulholland's 25" span CO² Ladvbird Special



Dave Wilkins did well with his **Simplex** and got himself onto the Top-10 Leader Board in Vintage Precision as well as Vintage IC Duration



Left: Robert's
the showers.

Right: Editor's
engine run to clear
but no flights.



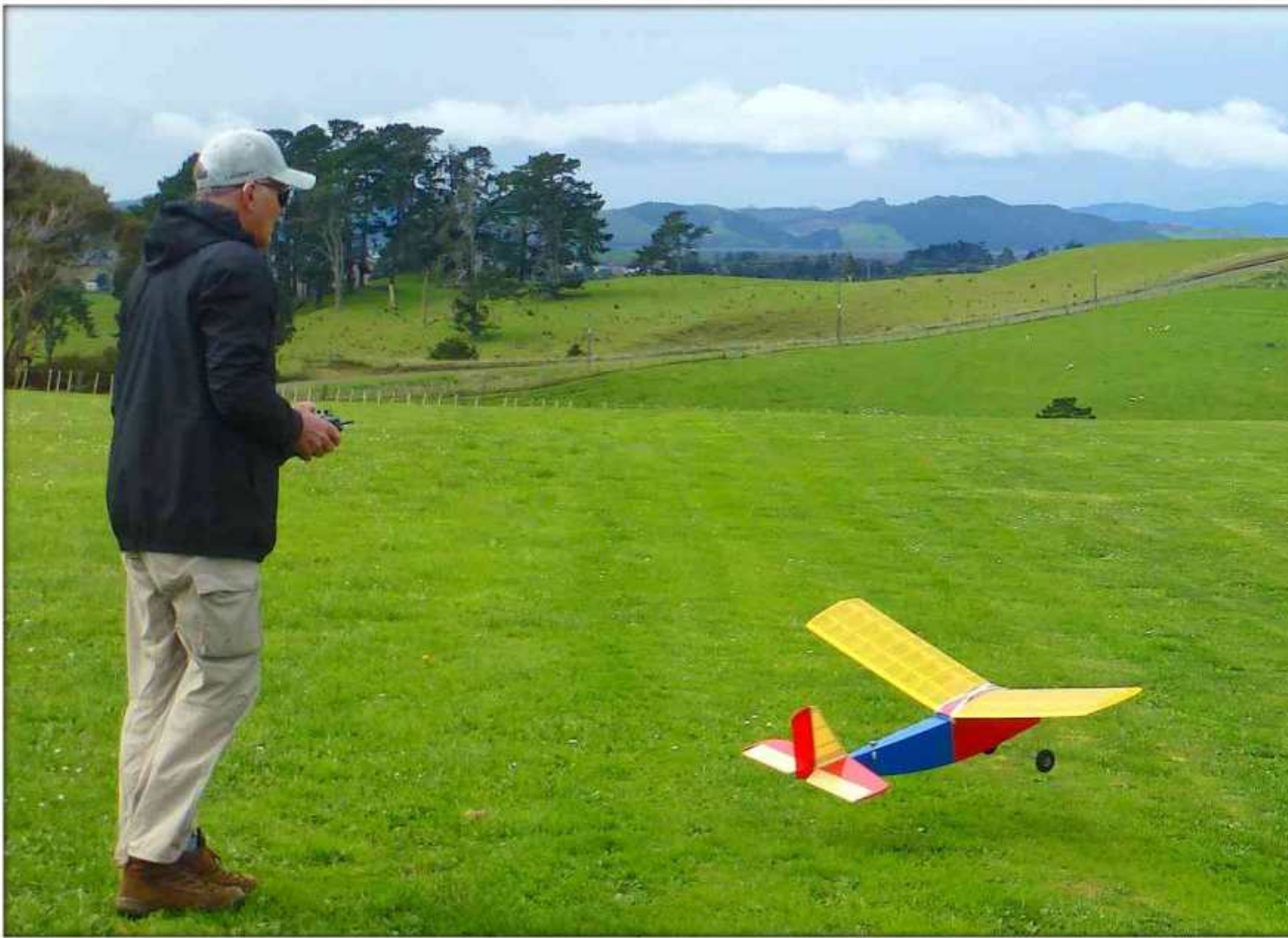

Tony Gribble Vintage Precision **Miss Fortune X** - 560

Tony also flew a **Gloworm** in Clasical E Duration for a score of 300, and a token flight in Vintage E Texaco after knocking the tail off his **Folly II**.



After replenishing the deuterium cores in the **Demon's** anti-matter thrusters, Mike was able to launch for Dave. ROG had been hampered by the loss of one wheel on a previous landing.

And, down South, CMAC never sleeps.
John Beresford and Lynn Rodway with
the models they, and Allan Knox, flew in
NDC on 19th Sept.



Vintage Aeromodelling at the Cinema



Out now is the sequel to Wes Craven's "Our Humming Bird Is Missing". "Return of the Humming Bird" is even more gastly than the pre-release shot at left, courtesy of Allan Knox. Fans of the series will be pleased to hear that one of the ever-green Mills Brothers, although now 75 and somewhat aged after many years of freedom camping, again has star billing.



The suggestion made in the last bulletin that the Pylonius column may have been written by Ray Malstrom was

questioned by John Dowling who writes "I am reasonably sure that Pylonius was not Ray Malmstrom. I think Pylonius was the

well-known rubber power flyer, Len Ranson". Can any British readers cast a light on this?

A search though back issues of Aeromodeller found what may be the first Pylonius column and this is reproduced below.

January 1951

Topical Twists

MALICE IN DUNDERLAND

(Reports of model aircraft being imperiously banned from parks and commons throughout the country are on the increase.)

The Red Queen, no one could deny,
Was given to a queer fixation.
"Off with their heads," she'd loudly cry
At the slightest provocation.
A drastic measure no doubt suited
To get one's orders executed.
But not a method to apply
In a wise administration.

And it seems a thousand pities
That this complex should obtain
In most all our towns and cities—
Adverse to the model plane—
Where welding bright and angry axes,
As their indignation waxes,
The Red Queens on our Park Committees
Show little feeling—less of brain.

Slope soaring is becoming very popular. Understandably so, since it ensures "peak" performance.

WAKEFIELD TOPICS

The much coveted Wakefield Cup, being won on two successive occasions by models using a return gear system, has prompted certain progressive elements in this country to experiment with this old/new idea. Having seen something of the elaborate gadgetry, the exhausting winding of two large, squirming motors, and the constructional ingenuity required to keep the total weight down to a reasonable level, I can only recommend the gear system to any singular individual possessing the patience of Job, the arm of Popeye, and the inventive genius of Heath Robinson.

Of course, the gear idea has its opponents, who are apt critically to refer to the amount of friction set up. This would seem to occur mainly between the winder and his helper.

Speaking of Wakefields, I recently sneaked in upon a preview of a model straight from the stocks of one of our leading exponents. This model, which seemed about as solid as the Rock of Gibraltar and as streamlined as Betty Grable, weighed approximately 8.00001 oz. The power was in the region of two strands of a quarter flat about a hundred yards long, and would absorb umpteen thousand turns. It had a climb like a flying saucer late for some interstellar appointment, and would only come down when spoken to in the kindest terms.

This is in direct contrast with our own Wakefield design—filched from all the best plans. As robust as sixpennyworth of Candy Floss, with an all up weight of 14 oz., this monstrosity will only reluctantly rise a few feet under the stimulus of twenty strands of quarter, and is more given to stalling than a politician.

Still, why should I worry when I can always blame it on to "fatigued" rubber.

From the winds of the North comes again the moan that the Southern bods enjoy all the best of this climate's paltry allotment of fine weather:

Men from the clouded Northlands raw
Marvelled at the sight they saw;
A huge and fiery ball on high
Above the cloudless Fairlop sky.
And there they stood and gazed in awe—
They'd never seen the sun before!

MODEL OLYMPICS

Hot on the trail of recent rumours that the next Olympics will feature certain model aircraft events, our Sporting correspondent, Al Rounder,—known as the "Man They Can't Gag," probably because of his receding chin—has managed to snoop out the proposed programme. All events will, of course, proceed from a flying start.

Javelin Throwing —A hand launched contest with this popular engine.
Relay Race —R/C around the circuit.
Cross Country Marathon —Includes all free flight events.
Shooting the Line —Open event for club bores.
Flicking the Prop. —The only event which will finish at the start.
Hop, Skip & Jump —Run in conjunction with previous event—best performances being obtained with a damaged finger.

By Pylonius

DUSTER

Flying Models, June 1959

Harry English

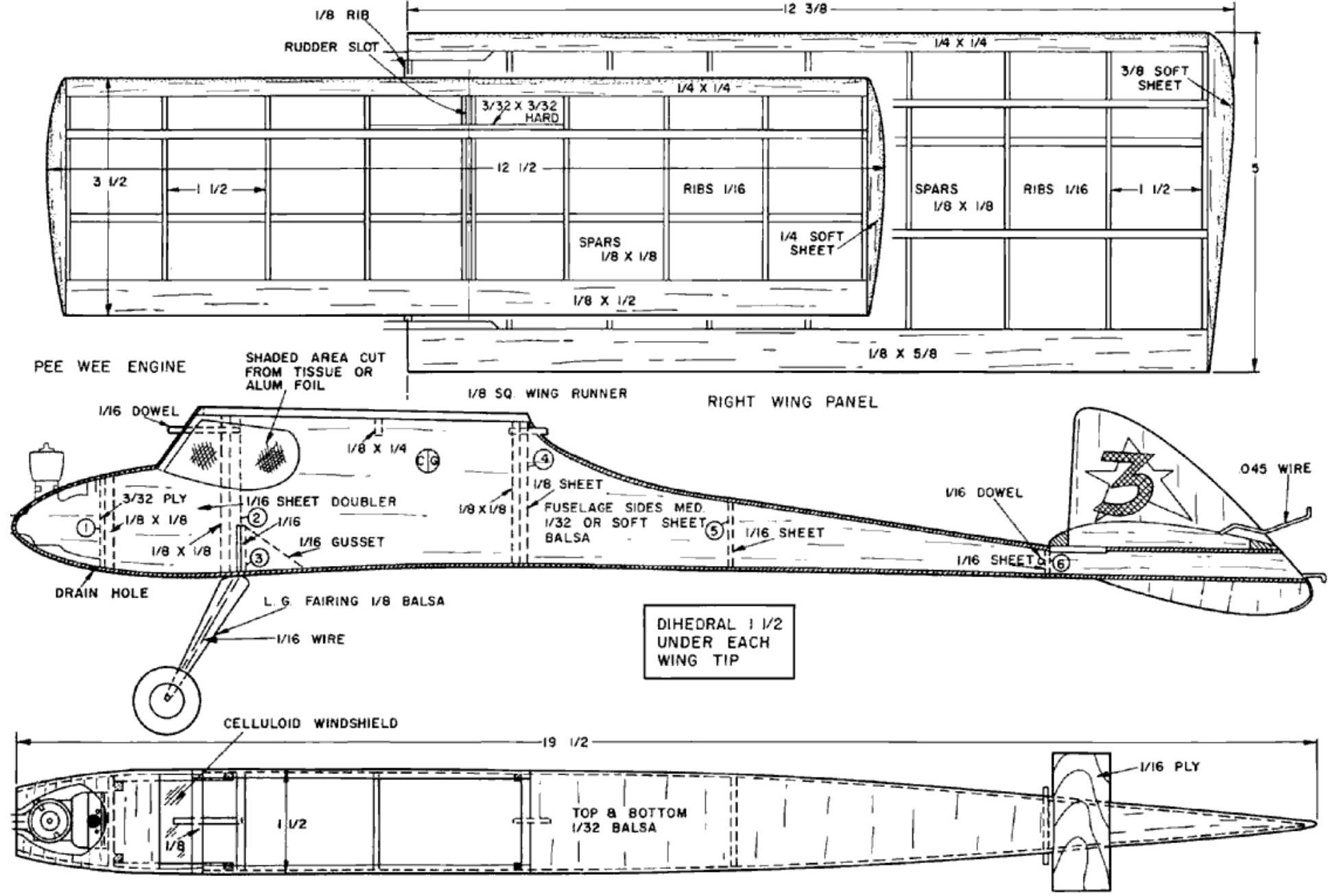

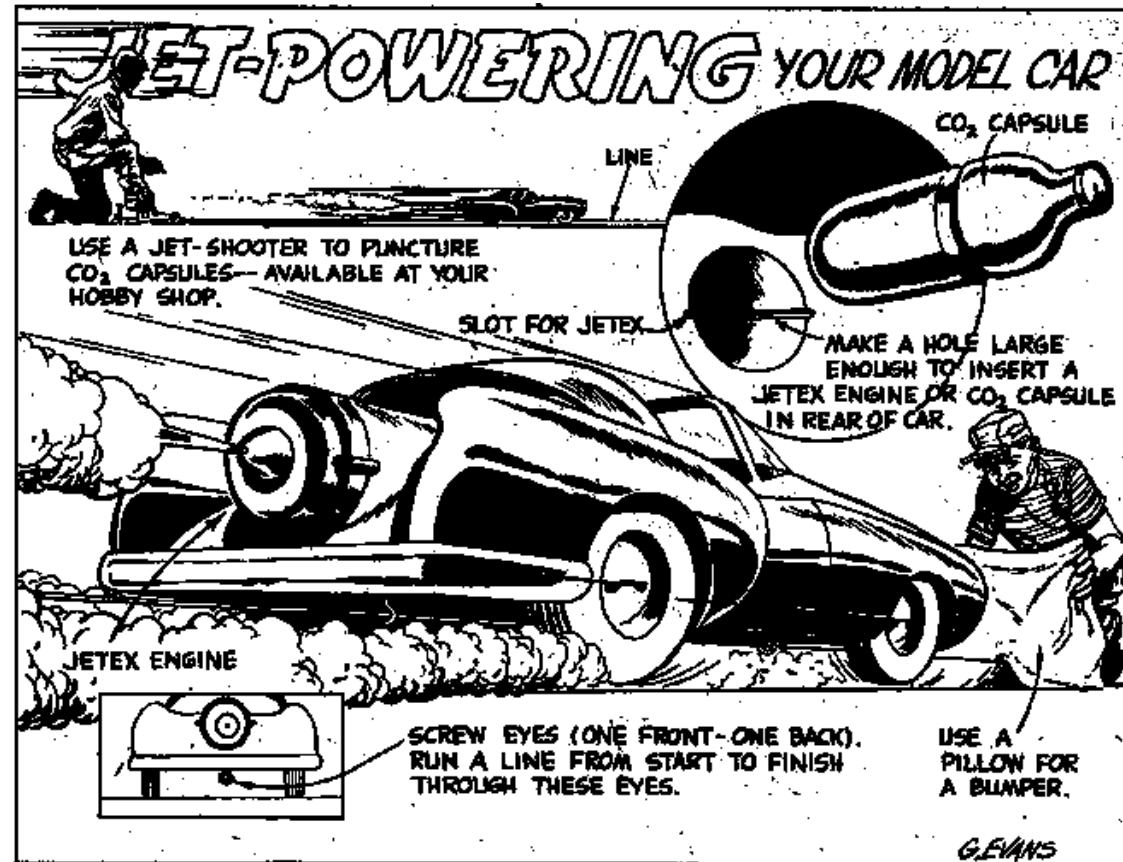
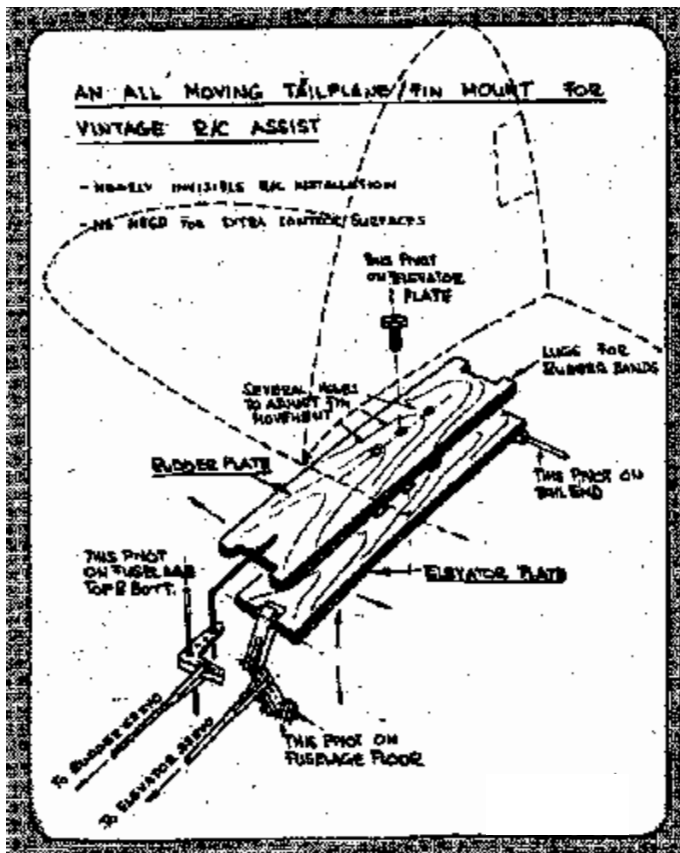
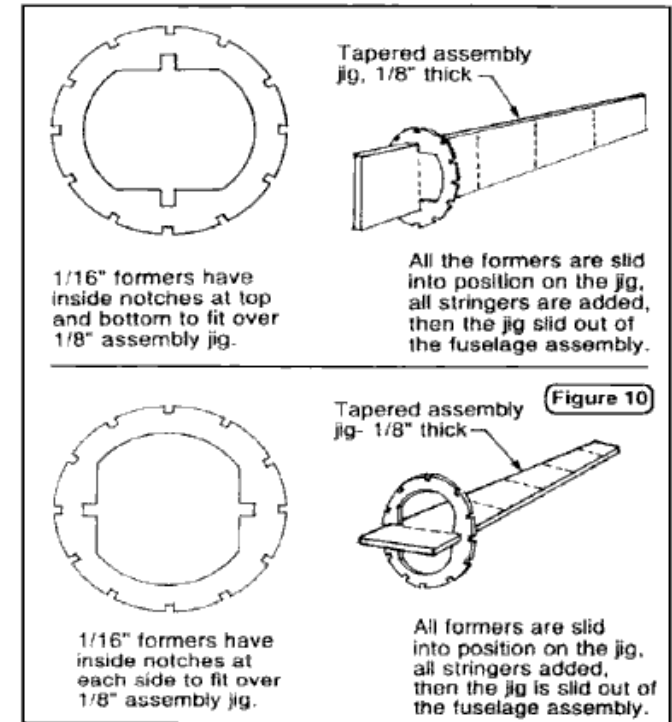
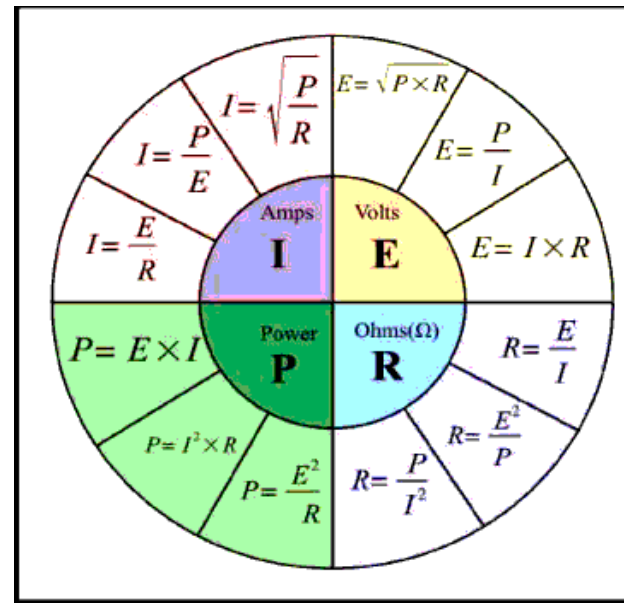
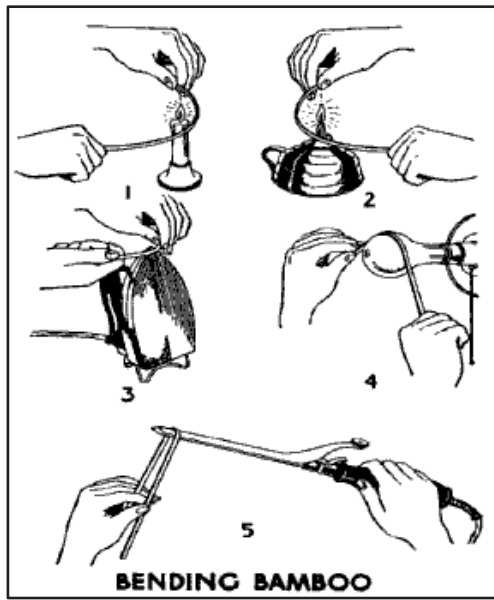

Bettair's BUSINESS BULLETIN

May 1960



Issued Monthly by the
"BETTA MODEL AEROPLANE SUPPLY CO."
P.O. BOX 260, NEW PLYMOUTH

THIS BULLETIN: If you desire to receive this monthly Bulletin each month, you must procure 12 standard size letter envelopes. Address these to yourself. In the top left-hand corner put the numbers 1 to 12, and on the top right-hand corner fix a 2d stamp. We use these envelopes in order, so when you receive the envelope with the number 12 in the top left-hand corner, you know it is time to send in another 12 envelopes.

Overseas Customers, please send name and address, printed if not typed. If in the Commonwealth please use a British Postal Order for 2/-. If in a foreign land please send International Reply Coupons to the total value of 2/-. Buy the lowest value possible, otherwise when we redeem same here we only get a maximum of 4d for each one.

BETTA MODEL AEROPLANE SUPPLY CO

182 DEVON STREET EAST NEW PLYMOUTH. P.O. BOX 260, NEW PLYMOUTH.

MAY BULLETIN MAY BULLETIN MAY BULLETIN MAY BULLETIN.

ENYA 15D MOTORS STILL A FEW LEFT at £3/15/0 each. No more for some months.

Please note, 3/16 in Dowell this was a mistake in last months bulletin, we do not have this in stock. Other sizes as quoted.

JETEX 50 FUEL, Also wicks and New Barrells for 50 Motors. More of these are now to hand fuel 3/- tin of 20, wicks 1/6 tin and new barrells 6d each.

Circuit Tester, we still have one of these left for the keen radio type who wants real value. English equivalent costs nearly £30. This one is only £7/10/0.

STRATO GLIDER, SPACE FLYER, STUNT FLYER, These are proving very popular, but we cannot land any more this year. We still have fair stocks, but would suggest that any one wanting xmas stock gets in now and put some away for the holidays.

MAY SCHOOL HOLIDAYS. Just a reminder that these are nearly on us. each year we get frantic requests, telegrams etc for stock which has been overlooked. Please order early.

PLANS. Thunderbird Nobler etc as per last months bulletin are going out by the dozen. Looks as though there will be plenty of these at the next nats. Have you got yours yet? We can really recommend the Chipmunk and Tempest. All 10/- each.

FOX 29x Motors, only one left who wants it? £7/15/0.

MINIWIRE CONTROL LINE WIRE, still some .008, at 2/3 120ft, and .010 at 2/3 and 3/9 reel, and 013 at 6/-

ENYA GLO PLUGS. Some more to hand at 3/- 2 volt, also 1 1/2 Volt at 5/3. O&R Quickfire plugs at 6/- Limited quantity.

WHEELS	3/8" AMERICAN	1 1/2" Pair	5/-
"	"	1 1/2" Sponge	5/-
"	"	1 1/2" Sponge streamline	5/- Pair
"	"	1 1/2" Sponge	6/- Pair
"	"	1 1/2" Sponge Streamline	6/- Pair
"	"	1 1/2" "	7/6 "
"	"	3in Pneumatic	21/- Pair (Cost Price)

Valve Spout cans just arrived 6/6 each.

SPECIAL PURCHASE BANKRUPT STOCK.

Coloured dope RED, BLUE GREEN YELLOW, 2oz bottles only at 12/- dozen. This is good quality dope bought cheap. So be in and stock up on it.

CATALOGUE, Has been promised to us this month, we have our fingers crossed and will forward orders as soon as it is to hand.

AEROMODELLER. We still have a few copies of the following issues in stock, Xmas issue with free plan, also April, May, July, Aug, Sept, Oct, Nov, all 1959.

Model Aircraft, July, Oct Sept Dec 1959.

R.A.T. Review, Sept, Oct, Nov, Dec, 1959 and Jan Feb March 1960

MINIPLANES. These are ideal for boat builders, 8/6 each.

TRIMBLEDRONE Fingerguards, save those fingers only 2/6 each. (Below Cost)

Elms Mini diesel Timers, we have found another box of these lying about. Out they go at 3/6 each.

Multicraft saw frames and two blades, to fit the Multicraft standard knife. 6/6 each. Sorry we are out of knives at the present.

Plastic Fuel Tubing (Clear) we have good stocks of this at 1/- foot or 2/6 per yard. This is English non hardening type.

PROPELLERS. Still some American Toronado Speed props left at 3/9 each.

"IDEAL" BLERIOT MONOPLANE

3 FOOT FLYING MODEL

SCALE = 1/2 FULL SIZE

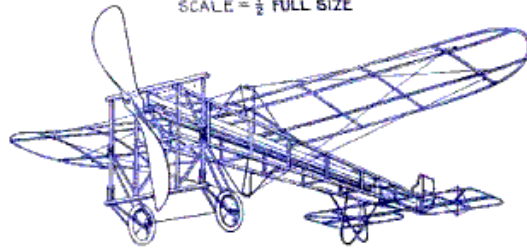

KEY TO PARTS	KEY TO MATERIAL
A Fuselage	a Wood
B Chassis	b "
C Main Planes	c "
D Tail	d "
E Elevators	e "
F Rudder	f diameter
G Skids	g "
H Propeller	h T-section
I Motor	i diameter
J Masts	j "
K Ball Bearing Propeller Shaft	k "
L Aluminum Propeller Hanger	l Steel Rod/Wire
M Aluminum Sleeves	m Aluminum "
N Shock Absorbers	n Rubber
O Pneumatic Tire Disc Wheels	o flat
P Rear Rubber Hook	p Tinned Wire

All Parts to construct this Model can be had from your Dealer or from the Manufacturers.

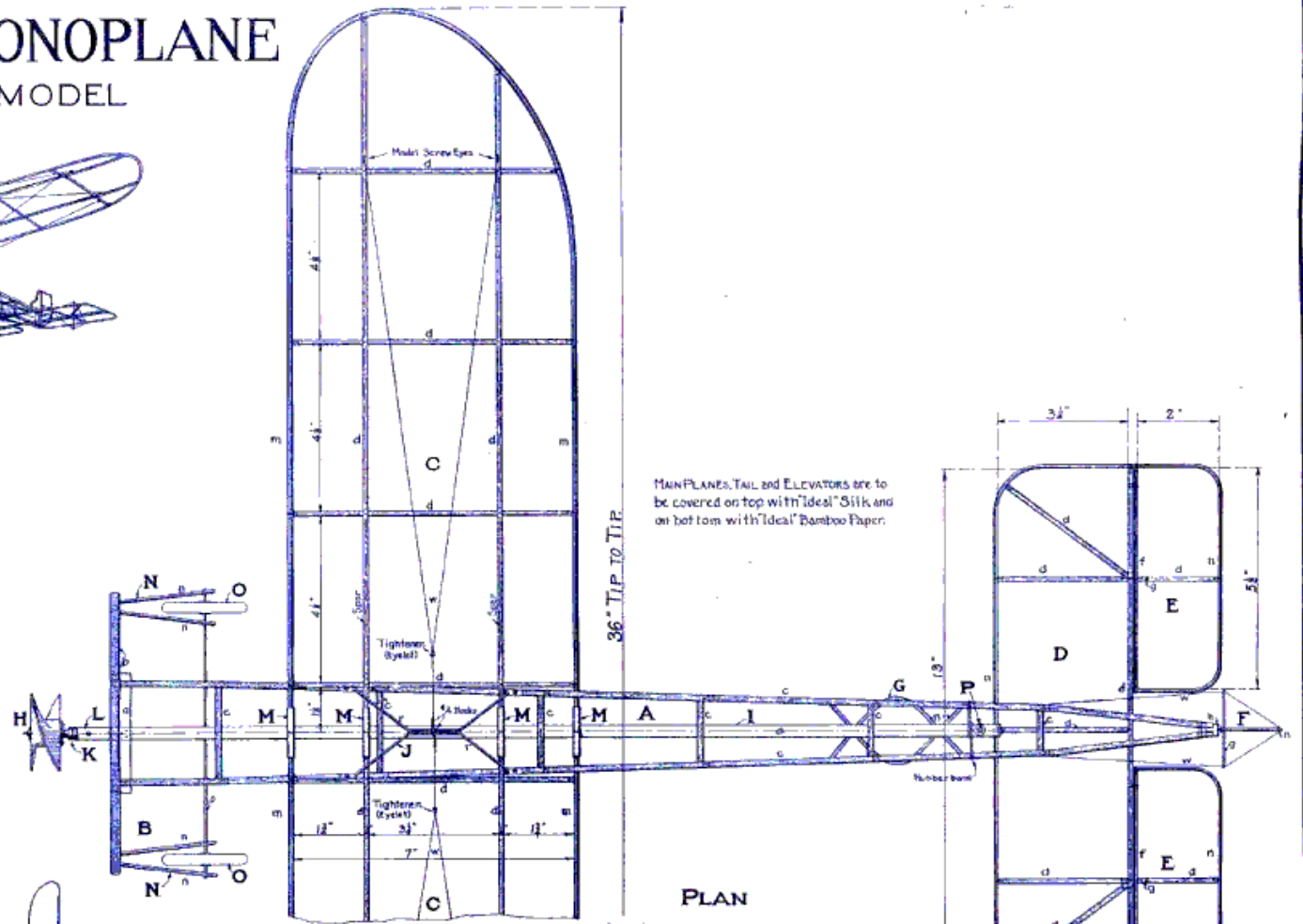

PLAN

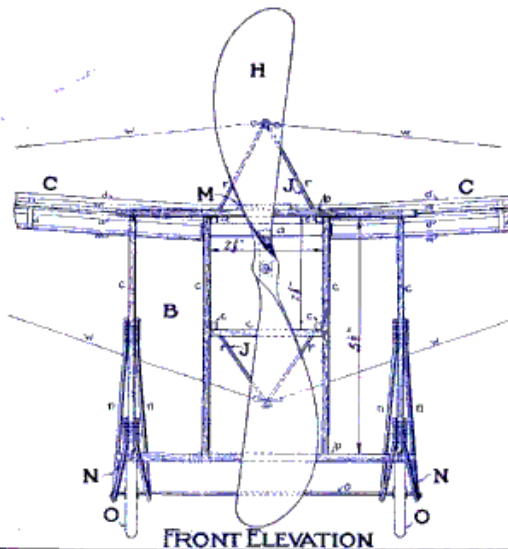

FRONT ELEVATION

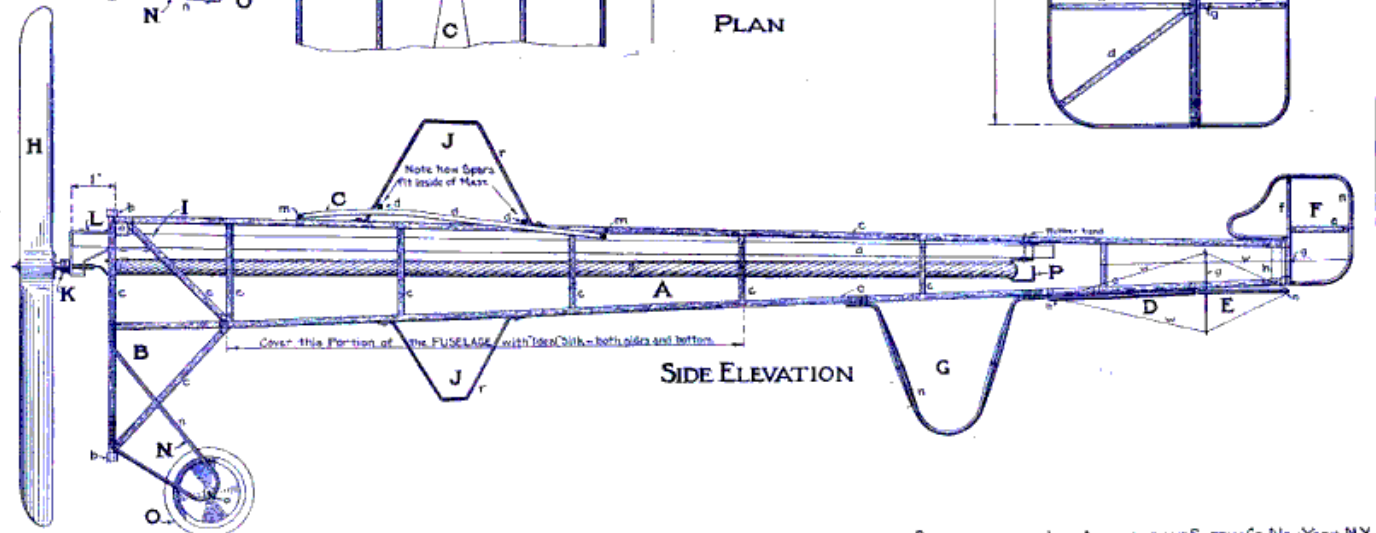

SIDE ELEVATION

COPYRIGHT, 1917, BY IDEAL AIRPLANE AND SUPPLY CO. NEW YORK, N.Y.

MAKE THE MOST OF THE AGE BONUS RULE

Plan Published 1917

Three Questions

Who are these 20th century aeronautical persons ?



(No, not a young Benny Hill)



Report of North Island RC Vintage Championships, 20-22 March 2015

CD's Report

This was a very enjoyable event that used a three-day format with a schedule of classes to be flown each day. The weather was good on all three days, with light to moderate variable breezes, mostly sunny but with some cloudy periods. Lift was mainly light but there were a few boomers. Some quite severe downdrafts delivered unexpectedly low scores on several flights.

Nineteen people registered, made 71 entries, and recorded 208 flights. Entries were very strong in Vintage Precision (15), Vintage IC Duration (9), and Vintage E Duration (9). All of the Vintage electric Texaco classes were well supported. However, after promising entry numbers at the Nationals, Classical IC Duration (2), Classical E Duration (1), and Open Texaco (0) still need much more support (please take note for winter building programmes!). It was good to see three entries in the new Classical Precision class – perhaps this is the route to expanding interest across all Classical flying.

The standard of flying was generally high, with fly-offs in four classes. The three contestants in the 1/2E Texaco fly-off all scored over 20 minutes – a highlight of the Championships.

This first attempt at a North Island championship was successful, although unfortunately there were no entries from outside the NNI region. It is likely that the SIG will decide to run the event every year, with venues alternating between the NNI and SNI regions, opposite to the location of the Nationals – giving all NI members easy access to at least one of them.

Wayne Cartwright

Results

		R1	R2	R3	Total	FO
Vintage Precision						
1	Gordon Meads Lanzo RC1	200	200	200	600	200
2	John Butcher Miss Fortune X	200	200	200	600	197
2	Brian Harris New Ruler	200	200	200	600	197
4	Graham Main Miss Trenton III	200	198	200	598	
5	Rex Anderson Trenton Terror	200	197	200	597	
6	Charles Warren So Long	200	196	200	596	
6	John Warner Record Breaker	196	200	200	596	
8	Dave Crook Bomber	200	199	191	590	
9	Graham Bradley Lanzo RC 1	200	184	200	584	

10	Don Mossop Bomber	200	197	186	583
11	David Thornley Bomber	189	189	200	578
12	David Gush Miss Fortune X	193	183	198	574
13	Martin Evans Trenton Terror	180	183	200	563
14	Doug Baunton Miss Arpiem	188	167	200	555
15	Keith Trillo Tomboy	143	171	177	491

Classical Precision

1	Brian Harris Humbug	197	197	200	594
2	David Thornley Satellite 1000	196	195	199	590
3	Don Mossop Super 60	179	195	197	571

Vintage IC Duration

1	John Butcher Miss Fortune X	260	260	260	780
2	David Thornley Bomber	252	252	260	764
3	Wayne Cartwright Bomber	260	260	237	757
4	Gordon Meads Playboy	260	250	218	728
5	Rex Anderson Playboy	231	148	250	629
6	David Gush Miss Fortune X	205	212	211	628
7	Graham Main Interceptor	171	163	260	594
8	Martin Evans Guff	162	179	161	502
9	Graeme Bradley Lanzo RC1	142	109	155	406

Open Texaco

None flew

Vintage A Texaco

1	John Butcher Lanzo RC1, PAW 19	620	616	620	1856
2	Charles Warren So Long, PAW 09	609	620	542	1771
3	Rex Anderson Cloud Snooper, OS 20FS	482	491	531	1504
4	Graham Main Simplex, OS 20FS	366	304	361	1031
5	Paul Evans Miss Fortune X, PAW 09	221	0	0	221

Vintage 1/2A Texaco

1	John Butcher Texaco 39	500	327	500	1327
2	Keith Trillo Skipper	500	185	442	1127
3	Martin Evans Miss Philadelphia IV	228	309	500	1037
4	Charles Warren Bomber	271	74	158	503



Vintage E Duration

1 Brian Harris	Playboy, 553 sqin 1000, 4S, 30C	320	320	320	960	530
2 Wayne Cartwright	Top Banana, 900sqin 1100, 5S, 35C	320	320	320	960	403
3 Keith Trillo	Stardust Spl, 508 sqin 800, 3S, 40C	320	310	320	950	
4 Stuart Lightfoot	New Ruler, 560 sqin 1350, 3S, 30C	310	310	320	940	
5 Don Mossop	Playboy, 770 sqin 1600, 4S, 25C	320	237	320	877	
6 John Butcher	Miss Fortune X, 600 sqin, 3S, 20C	204	315	320	839	
7 Rex Anderson	Anderson Pylon, 580 sqin, 3S, 30C	211	313	260	784	
8 Doug Baunton	Miss Arpiem, 596sqin 2200, 3S, 20C	214	228	210	652	
9 John Warner	Playboy, 510 sqin 1000, 3S, 20C	224	320	158	612	

Vintage E Texaco

1 John Butcher	Miss Fortune X 600 sqin, 540, 2S, 25C	620	620	620	1860	560
2 Keith Trillo	Stardust Spl 508 sqin, 450, 2S, 25C	620	620	620	1860	535
3 Wayne Cartwright	Cruiser, 643 sqin, 550, 2S, 25C	620	620	534	1764	
4 Rex Anderson	Kerswap, 400 sqin 360, 2S, 20C	620	492	620	1732	
5 Dave Crook	Bomber, 742 sqin 610, 2S, 20C	620	529	539	1688	
6 Doug Baunton	Miss Arpiem 360, 3S, 35C	460	426	458	1354	

Vintage 1/2E Texaco

1 John Butcher	Miss FX, 216 sqin	740	740	1480	1416
2 Wayne Cartwright	Arrow Nut, 216 sqin	740	740	1480	1336
3 Rex Anderson	Tomboy, 216 sqin	740	740	1480	1286

4 Keith Trillo	Stardust Spl, 207 sqin	740	730	1470
5 Bryan Spencer	Slicker, 246 sqin	740	723	1463
6 Martin Evans	Brigadier, 306 sqin	614	740	1354

Vintage E Rubber Texaco

1 Wayne Cartwright	Lanzo D, 335 sqin 300, 2S, 25C	620	620	620	1860	863
2 David Gush	Rocket Stick 270 sqin, 240, 2S, 25C	620	620	620	1860	787
3 Doug Baunton	JA Skokie, 272 sqin 240, 2S, 25C	534	568	620	1722	
4 Graham Main	KK Gipsy, 200 sqin 180, 2S 25C	432	456	421	1309	

Classical IC Duration

1 David Thornley	Satellite 1000 OS 46FX	178	266	287	731
2 Wayne Cartwright	Amazoom, ASP 46	144	93	0	237

Classical E Duration

1 Wayne Cartwright	Nig Nog, 623 sqin 1300, 4S, 35C	300	143	0	443
--------------------	------------------------------------	-----	-----	---	-----

Tomboy IC

1 Rex Anderson	Doonside Mills .75	811	621	1432
2 Jack Godfrey	Mills .75	727	128	855
3 Charles Warren	Mills .75	527	280	807
4 Rex Bain	Mills .75	254	501	755

Tomboy E

1 Rex Anderson	180, 2S	1119	663	1782
2 Bryan Spencer	180, 2S	1007	435	1442
3 Keith Trillo	180, 2S	479	542	1021

NEW! DYNAMIC!

Free Flight too tiring?
Control line old hat?

Never fear, the great new flying
challenge has arrived!

Test your reflexes with these
astonishing "Shadow Planes"!

Control your very own model at
the end of your very own stick!

Cast everchanging shadows to
thrill and amaze your friends!

Organise Shadow Plane rallies
and competitions to be the envy of
the neighborhood!

Attract girls by building a healthy
and attractive body in no time!

Become more popular than that
damned Billy Hodges and his new
trolley with the silver wheels!

Why buy a airplane that actually
flies, with an engine that really
runs, when you can have your own
thrilling Shadow Plane?

MEGOW
SHADOW Planes
SHADOW

THE NEW
MEGOW
"Mustang"
P-51 NORTH AMERICAN
FIGHTER

Balsa Kit scale model of the P-51
North American Mustang fighter.
12½-in. wingspan.
Kit No. SD-2.....\$1.50

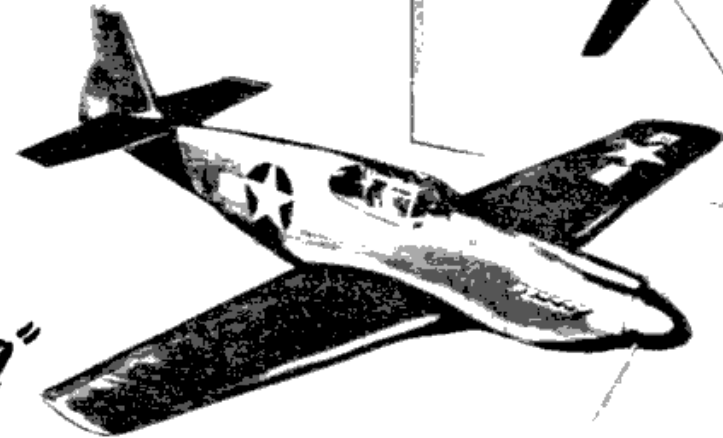

EASY-TO-BUILD SOLID MODELS
for **SHADOW-FLYING Fun!**

*Split-Second Identification
from Every Angle*

Cablon or Pybin ?



Contests divided by Cabin or Pylon configuration would have a problem with the 1943 **Cyklon**.

It is the work of Ladislav Neubert who may be remembered for his more conventional **NE-LA 541 B** (below) which featured in an earlier bulletin.

Like many plans from the war years, it appears to have been drawn for fretted hardwood, but conversion to ply and balsa would make for easier construction.

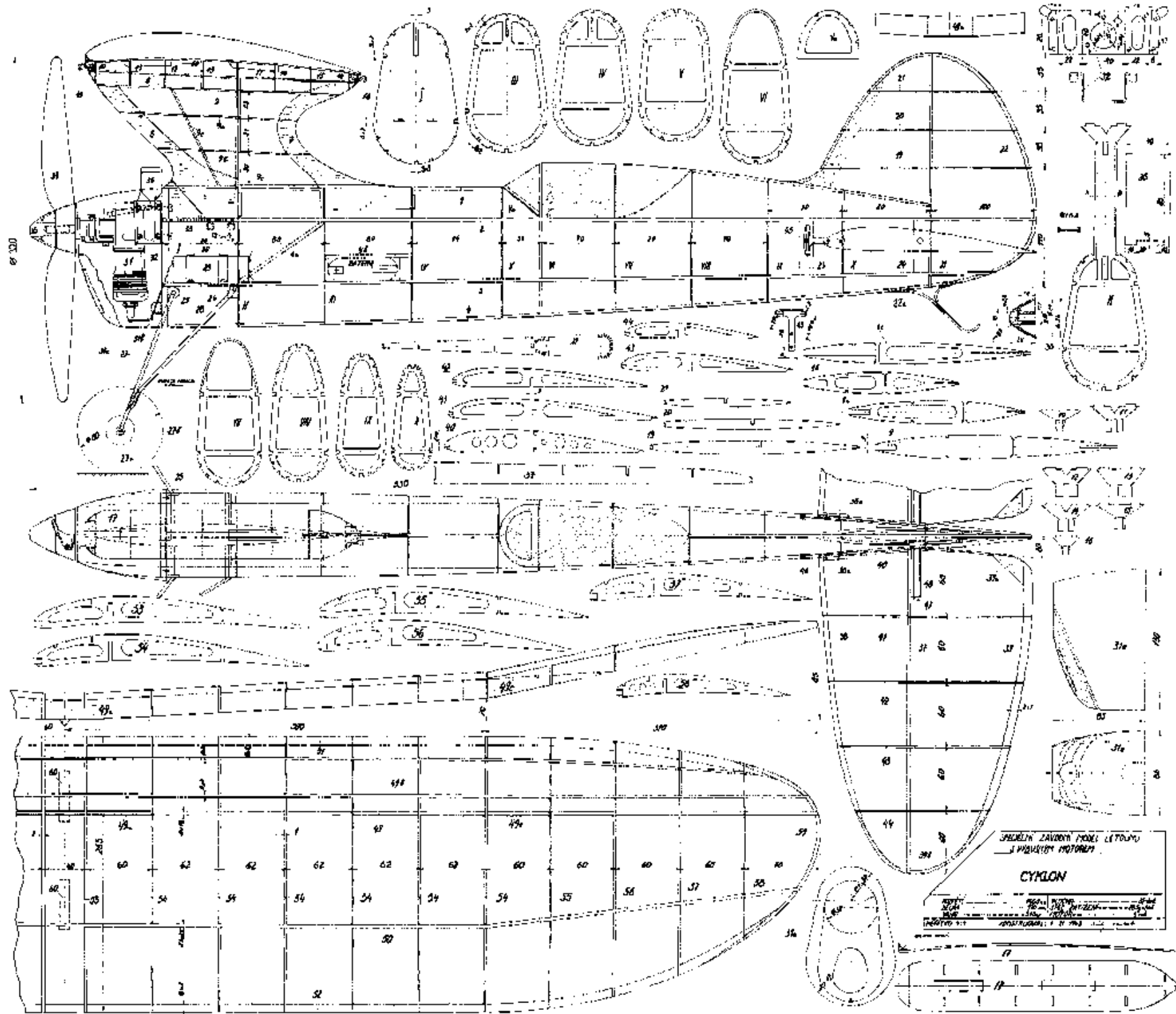



A de-termaliser orn a scale model ? ... orn a scale model ? 'Orrible, 'orrible ! ...

... unless you cleverly conceal it, that is. The method below was devised by Tom Hallman and was published in Flying Models, April 2012.



Scientific Fairchild 24 (above left) sports a barely visible and improved dethermalizer system that is totally non-intrusive, while at the same time being very effective in popping up (above right) the



entire rudder and stabilizer unit to a 45-degree angle. It is actuated by a hidden viscous timer on the underside of the beautifully rendered craft and a small music wire spring embedded in the structure at the leading edge of the stabilizer.

RC Top **10** Leader Board 2022

Standings at 27th Sept



RC Top 10 Leader Boards 2022

The purpose of the Vintage SIG RC Leader Boards is to increase enjoyment of competition flying by showing fliers how well they are performing relative to others. Scores are posted from the results of contests, NDC, and independently-timed flying.

The Leader Boards run for each calendar year, and are updated throughout. At the end of each year they are cleared and started afresh.

Postings made since the last publication in AVAAZ News are shown in red.

Please email me if you spot any errors or omissions.

Wayne Cartwright
rwcartwright4@gmail.com

Precision Classes

Vintage Precision

1.	D Crook	600 + 199
2.	K Daly	600 + 195
3.	A Knox	600 + 192
4.	D Mossop	600 + 172
5.	D Wilkins	600
6.	R Berger	596
7.	B Russell	582
8.	T Gribble	582
9.	B Treloar	580
10.	S Cox	580

Classical Precision

1.	A Knox	600 + 199
2.	B Russell	600 + 191
3.	D Mossop	600 + 186
4.	S Nicholas	595
5.	B Robinson	589
6.	B Perriam	589
7.	G Fulton	585

Duration Classes

Vintage IC Duration

1.	D Wilkins	780 + 596
2.	P Townsend	760
3.	A Knox	740
4.	B Treloar	675
5.	B Russell	665
6.	T Beaumont	495
7.	K Daly	445
8.	J Ryan	413
9.	J Miller	240
10.	D Little	229

Vintage E Duration

1.	S Nicholas	960 + 600
2.	D Mossop	960 + 379
3.	B Russell	960
4.	A Knox	940
5.	A Hales	920
6.	S Hubbard	790
7.	B Robinson	796
8.	T Gribble	658
9.	P Townsend	554
10.	G Fulton	380

Classical IC Duration

1.	P Townsend	891
----	------------	-----

Classical E Duration

1.	B Russell	900+600+384
2.	M Shears	900 + 545
3.	D Mossop	900 + 492
4.	S Nicholas	900 + 313
5.	D Crook	900
6.	D Gush	888
7.	A Knox	885
8.	B Robinson	874
9.	W Cartwright	860
10.	D Barber	809

RC Top 10 Leader Board 2022

Standings at 27th Sept



Texaco Classes

Vintage 1/2A Texaco

1.	S Cox	1500 + 1020
2.	A Knox	1500 + 929
3.	B Scott	1500 + 512
4.	P Townsend	1480
5.	L Rodway	1460
6.	J bersford	1460
7.	B Treloar	1387
8.	J Ryan	1333
9.	S Morse	761
10.	D Little	741

Vintage A Texaco

1.	P Townsend	1860 + 1418
2.	A Knox	1860
3.	B Treloar	1840
4.	B Scott	1472
5.	I Munro	1342

Vintage Open Texaco

1.	A Knox	1840
2.	L Rodway	1406
3.	P Townsend	1407
4.	I Munro	1234

Vintage 1/2E Texaco

1.	B Russell	2443
2.	A Knox	2111
3.	T Gribble	1619
4.	W Cartwright	1501
5.	B Scott	1073
6.	L Rodway	837
7.	P Townsend	212
8.	D Mossop	82

Classical 1/2E Texaco

1.	L Rodway	1463
2.	D Mossop	1312
3.	A Knox	1197

Vintage E Texaco

1.	A Knox	3593
2.	W Cartwright	2142
3.	B Russell	1537
4.	B Scott	1345
5.	D Mossop	1147

Classical E Texaco

1.	A Knox	3900
2.	W Cartwright	2194
3.	D Mossop	1326
4.	B Russell	1086
5.	T Gribble	1076
6.	P Townsend	964

Vintage E Rubber Texaco

1.	D Mossop	4679
2.	D Gush	4161
3.	D Crook	3075
4.	B Scott	2425
5.	W Cartwright	2318
6.	B Russell	2255
7.	A Knox	1572
8.	P Townsend	360

Sport Cabin Texaco IC

1.	A Knox	1827
2.	J Beresford	1619
3.	L Rodway	1208
4.	S Morse	443

Sport Cabin Texaco E

1.	P Townsend	1845
2.	B Russell	1445
3.	B Robinson	894
4.	M Evans	780
5.	L Rodway	754

Vintage and Classical Scale Texaco

1.	A Knox	1660
----	--------	------

FF Top 10 Leader Board 2022

Standings at 1 June



Vintage Precision

1. B.Gibson	226
2. L.Rodway	210
3. W.Long	188
4. R.Bould	143
5. S.Morse	61

Nostalgia Rubber Duration

Classic Glider Duration

1. L.Rodway	237
2. A.Knox	210

Nostalgia Glider Duration

Vintage Power Duration

1. R.Bain	540
-----------	-----

Vintage Rubber Duration

1. A.Koerbin	540
2. P.Squires	490
3. W.Lightfoot	322
4. L.Rodway	231
5. S.Morse	213
6. J.Bersford	173
7. B.Gibson	78

Nostalgia Power Duration

1. L.Rodway	212
2. R.Bain	180

Classic Rubber Duration

1. W.Lightfoot	523
----------------	-----

Classic Power Duration

Small Power Duration

1. L.Rodway	187
2. S.Morse	143

Vintage Glider Duration

1. W.Lightfoot	409
----------------	-----



Ongoing Records from past Leader Boards

Oct 2022

RC Vintage Precision Allan Knox 2021	1194
RC Classical Precision Allan Knox 2021	599
RC Vintage IC Duration Stew Cox 2019	1671
RC Vintage E Duration Brian Harris 2018	1560
RC Classical IC Duration David Thornley 2017	1500
RC Classical E Duration Peter Townsend 2021	2700
RC Vintage 1/2A Texaco Allan Knox 2018	3333
RC Vintage A Texaco Allan Knox 2018	3730

RC Vintage Open Texaco Bryan Treloar 2018	3543
RC Vintage 1/2E Texaco Allan Knox 2021	3957
RC Classical 1/2E Texaco Allan Knox 2021	3266
RC Vintage E Texaco Allan Knox 2020	3000
RC Vint E Rubber Texaco Peter Townsend 2021	7988
RC Sport Cabin Texaco IC Sean McCurrie 2021	1646
RC Sport Cabin Texaco E Keith Trillo 2019	4456
RC Scale Texaco Allan Knox 2020	2466

FF Vintage Precision Gary Burrows 2014	411
FF Vintage Glider Rex Anderson 2018	436
FF Classic Glider Martin Evans 2015	470
FF Vintage Rubber W McGarvey / A Koerbin	540
FF Nostalgia Rubber Bill McGarvey / Bernard Scott	540
FF Vintage Power R Anderson / R Bain / B Scott	540
FF Nostalgia Power R Bain / B Scott	540
FF Small Power Bernard Scott 2016	353
FF Catpult Glider John Butcher 2012	339

The LAST STRAW

Answers

1. Frank Whittle
 2. Manfred von Richthofen
 3. Jean Batten
-

Right:

After the euphoria of completing his model aeroplane wore off, young Grayson Furniss was tormented by a dilemma.

On the one hand, he was sorely tempted to follow Uncle Uria's urgings and to take up the adventurous life of an airman.

What with the spot of bother in Suez, it seemed the right time to forgo personal ambition and jolly well pitch in for King and Country.

And, what a smashing time it would be with all his old chums - out East sunbathing, playing cricket, and bombing camels.

On the other hand, once he was in service, Aunt Polygamy's Sunday teas and her sublime scones (with lashings whipped cream) would be dreadfully missed !

